

mod. **BC5T**

| cod. 06800000

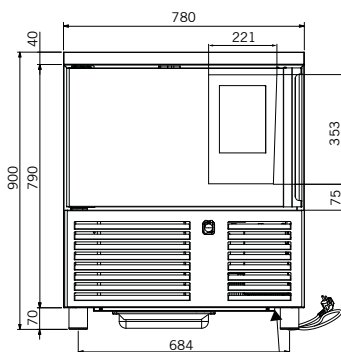

POWER CABLE OUTPUT 220-240 V / 50 Hz
L=3000m + SCHUKO PLUG SUPPLIED

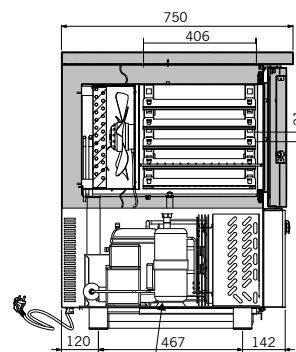

! WATER DRAINAGE Ø 20 EMPTY THE TRAY PERIODICALLY

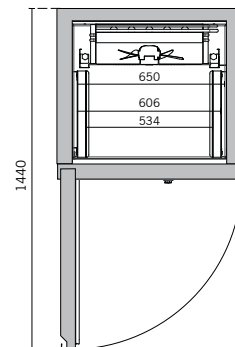

EN TECHNICAL SPECIFICATIONS

Temperature range (°C)	Dimensions W x D x H (mm)	Packaging dimensions W x D x H (mm)	Refrigerant gas	Capacity (L)	Climate class	Power consumption (W)	Supply voltage
-40 / +80	780 x 750 x 900	900 x 850 x 1250	R290	89	4	1270	220-240 V / 50 Hz

EN TECHNICAL AND FUNCTIONAL FEATURES

- Blast chiller - 5 1/1 GN 60x40 trays
- Ventilated refrigeration, motor inside the technical compartment
- Interior walls, structure and door made of AISI 304 stainless steel
- Rounded internal corners to facilitate cleaning operation
- Self-closing door with magnetic seal
- 60 mm thick insulation made of high pressure injected polyurethane with HFO blowing agent and 42 kg/m³ density
- Cataphoresis-treated evaporator for high corrosion resistance
- 7" color Touch Display control panel in 5 languages
- Blast chiller operating modes: Blast chilling - Freezing - Thawing - Defrosting - Slow cooking at a low temperature - Leaving - Ice cream hardening - Drying - Neutralizing bacteria in raw fish
- Customizable recipe book with 4 settable consecutive functions
- HACCP alarm storage
- USB port to upload and download data
- Needle probe for providing precise control of temperature
- 5 pairs of slideways included
- One stainless steel 1/1 GN wire-shelf and one 60x40 wire-shelf included
- From -40°C to +80°C operating cycles
- Chilling yield: 25 kg +70°C/+3°C
- Freezing yield: 10 kg +70°C/-18°C
- Adjustable stainless-steel legs
- Automatic condensate drain tray
- Condensate drain pan under the chiller bottom
- Maximum room temperature of 30°C with 55% humidity equivalent to climate class 4

OPTIONAL

- 1/1 GN Stainless steel grid
- 60 x 40 Stainless steel grid
- 1/1 GN Stainless steel tray H 20
- 1/1 GN Stainless steel tray H 40
- 1/1 GN Stainless steel tray H 65
- Large stand