



n.	2
ø mm	95
kW	6
kcal/h	5.160
Btu/h	20.472



TOT

kW	12
kcal/h	10.320
Btu/h	40.944



G30/G31 Kg/h	0,95
G20 m3/h	1,27
G25 m3/h	1,48



Kg	26
----	----

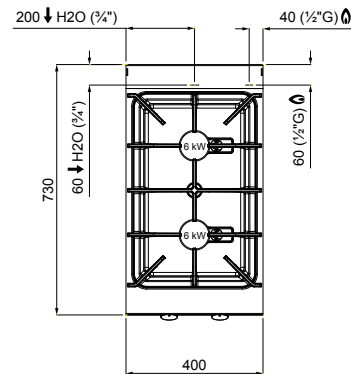
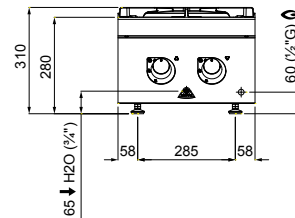

**OPTIONAL**

SG7F2B/SC - Cod. 07701010

Circolazione acqua nell'invaso con troppopieno • Water circulation inside the depression utilizing an overflow  
 Circulation de l'eau dans le contour du logement avec trop-plein • Wasserzirkulation innerhalb der gasmulde mit überlaufstopfen

**CARATTERISTICHE TECNICHE E FUNZIONALI**

Piano di lavoro in acciaio inox AISI 304 con spessore 20/10, pannelli frontali e laterali in acciaio inox AISI 304, finitura Scotch Brite.

Brucciatori in ghisa e spartifiamma in ottone fissati a tenuta di liquidi al piano in acciaio AISI 304 a profondo stampaggio. Garantiti a vita e azionati da rubinetto valvolato. Dotati di termocoppia di sicurezza e di fiamma pilota protetta da copertura in acciaio per una facile pulizia e manutenzione.

**TECHNICAL AND FUNCTIONAL FEATURES**

Worktop in AISI 304 stainless steel with a 20/10 thickness, front and side panels in AISI 304 stainless steel, Scotch Brite finishing.

Cast iron burners and brass burner cap, attached with a waterproof seal to the deep drawn worktop in AISI 304. Guaranteed for life, activated by a valve cock. Models equipped with safety thermocouple and burner pilot flame protected by a steel cap designed for easy cleaning and maintenance.

**CARACTÉRISTIQUES TECHNIQUES ET FONCTIONNELLES**

Plan de travail en acier inoxydable AISI 304 d'une épaisseur de 20/10, panneaux avant et latéraux en acier inoxydable AISI 304, finition Scotch Brite. Brûleurs en fonte et diffuseurs de flamme en laiton étanches aux liquides scellés au plan en acier AISI 304 à moulage profond. Garanties à vie et actionnés par un robinet à vanne. Dotés de soupape de sécurité à thermocouple et de flamme pilote protégée d'un couvercle en acier pour faciliter les opérations de nettoyage et de maintenance.

**TECHNISCHE UND FUNKTIONELLE EIGENSCHAFTEN**

Arbeitsfläche aus rostfreiem Edelstahl AISI 304, Stärke 20/10, Vorder- und Seitenwände aus rostfreiem Edelstahl AISI 304, Ausführung Scotch Brite.

Brenner aus Gusseisen und Flammenteiler aus Messing, flüssigkeitsdicht an der tiefgezogenen Arbeitsfläche aus rostfreiem Edelstahl AISI 304 befestigt, mit unbegrenzter Garantie und Steuerung mittels Ventilhahn. Mit Sicherheits-Thermoelement ausgestattet. Zündflamme mit Stahlabdeckung, für eine besonders leichte Reinigung und Wartung.

